

Premium EW

Hydronic Heat Pumps

- R-410A Refrigerant
- 2 thru 5 Tons

Installation Information

Water Piping Connections

Electrical

Startup Procedures

Troubleshooting

Preventive Maintenance



Premium EW Installation Manual



GEOSMART
ENERGY

IM1469 09/04

GeoSmart Energy

Premium EW



Model Nomenclature

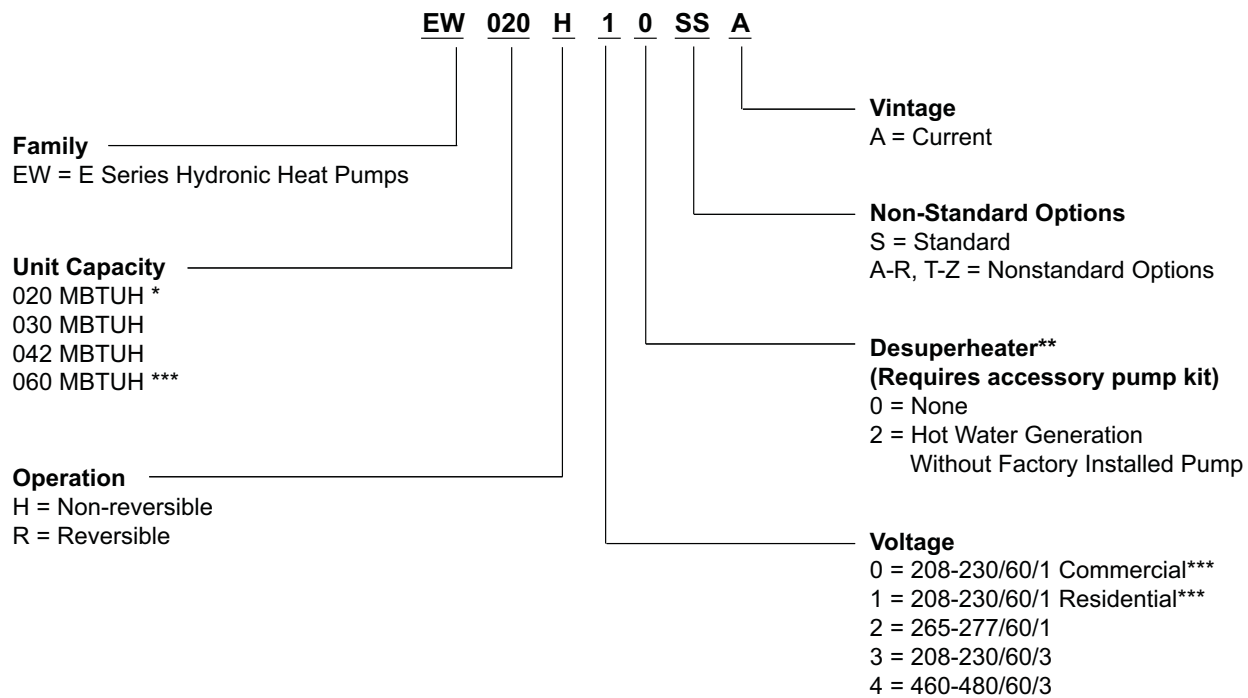

Notes: * EW020 is a heating only unit; vented coax is standard, no options.
 ** Available on 042 and 060 only.
 *** EW060 is not rated for 208/60/1 volt operation.

Table of Contents

General Installation Information	4
Accessories & Other Options	5
Potable Water Systems	6-7
Open Loop Systems	8
Earth Coupled Systems	9
Electrical	10-11
Schematics	12-13
External Control	14-15
Staging	16-17
Converting to a Dedicated Cooling Unit	18
Unit Startup	19
Control Panel, Parameters & Operation Modes	20-21
Capacity Data	22
Flow Rates & Pressure Drop	23-24
Troubleshooting	25-26
Preventive Maintenance	27

General Installation Information

Safety Considerations



WARNING: Before performing service or maintenance operations on the system, disconnect all power sources to unit. Electrical shock could cause personal injury. Before applying power to the unit, make sure that all panels and screws are in place. Failure to do so could cause risk of electrical shock.

Safety Advisements

Installation and servicing of heating and air conditioning equipment can be hazardous due to system pressure and electrical components. Only trained and qualified service personnel should install, repair or service heating and air conditioning equipment.

When working on heating and air conditioning equipment, observe precautions in the literature, tags and labels attached to the unit as well as other safety precautions that may apply, such as the following safety measures:

- Follow all safety codes.
- Wear safety glasses and work gloves.
- Use a quenching cloth for brazing operations.
- Have a fire extinguisher available for all brazing operations.

Moving and Storage

Move units in the normal “up” orientation. Do not stack more than two units in total height. When the equipment is received, all items should be carefully checked against the bill of lading to be sure that all crates and cartons have been received. Examine units from the cartons if necessary. Units in question should also be internally inspected. If any damage is noted, the carrier should make the proper notation on the delivery receipt, acknowledging the damage.

Unit Location

Locate the unit in an indoor area that allows easy removal of the access panels and has enough space for service personnel to perform maintenance or repair. Provide sufficient room to make water and electrical conditions. Units may be stacked vertically in small mechanical rooms. These units are not approved for outdoor installation and, therefore, must be installed inside the structure being conditioned. Do not locate in areas subject to freezing.

Piping

Both source as well as load fluid piping must be at least as large as the unit connections on the heat pump (larger on long runs).

Process Water Applications

For process water applications, it is recommended that a secondary load heat exchanger be installed to prevent corrosion to the unit’s primary coaxial coil. In situations where scaling could be heavy or where biological growth such as iron bacteria will be present, a closed loop system is recommended. Over a period of time, ground water unit heat exchanger coils may lose heat exchange capability due to a buildup of mineral deposits. These can be cleaned only by a qualified service mechanic as special pumping equipment and solutions are required. Never use flexible hoses with a smaller inside diameter than that of water connections.

Mounting Units

Units should be mounted level on a vibration absorbing pad slightly larger than the base to provide isolation between the unit and the floor. It is not necessary to anchor the unit to the floor. Allow access to front access panel for servicing compressor.

Figure 1: Unit Mounting

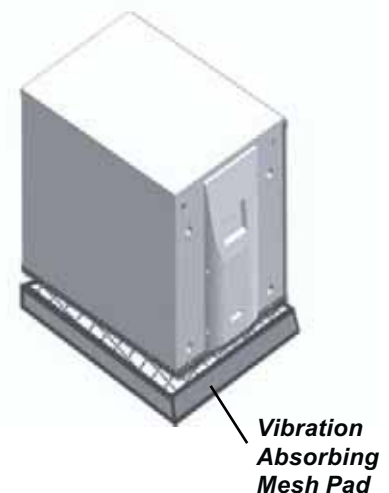

Accessories and Other Options

Water Connection Kits (Field Installed)

Water connection kits have been designed to facilitate load-side and loop-side water connections. See IM1470 for more information.

Earth Loop Pump Kit (Field Installed)

A specially designed one or two-pump module provides all liquid flow, fill and connection requirements for independent single unit systems (230/1/60 only). The one-pump module is capable of 25 feet of head at 16.0 GPM, while the two-pump module is capable of 50 feet of head at 16.0 GPM.

Desuperheater (Factory Installed, EW042 and EW060 Only)

An optional heat reclaiming desuperheater coil constructed of vented double-wall copper construction suitable for potable water is available. The coil is factory mounted inside the unit. A DPK5 pump kit is required (field installed), which includes a DHW tank connection and a temperature limit pump shutoff.

Load-side Pump Kit (Field Installed)

Load pump kits are available to provide all liquid flow requirements for independent single unit systems (230/1/60 only). For the EW020 a Grundfos UP15-42B5 (part number 24P501A04) is recommended for applications which require low flow. To select the proper pump, be certain that the system pressure drop is calculated correctly.

For higher flow applications, a Grundfos UP26-116 (part number EWPK1) is available. Refer to the Pump Curves in Figures 2 and 3 to ensure that the application fits under the pump. If the job requirements are outside the pump curve, an alternate pump will need to be obtained to maintain the necessary flow.

Figure 2: 24P501 - Pump Curve

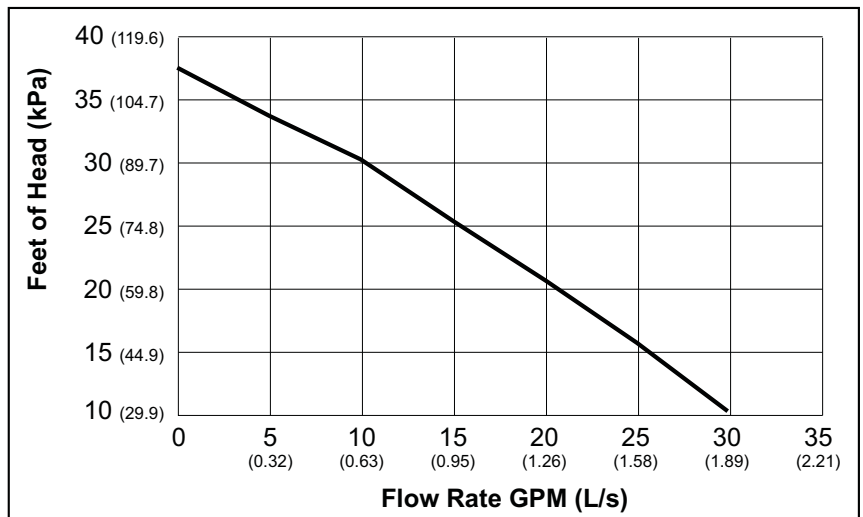
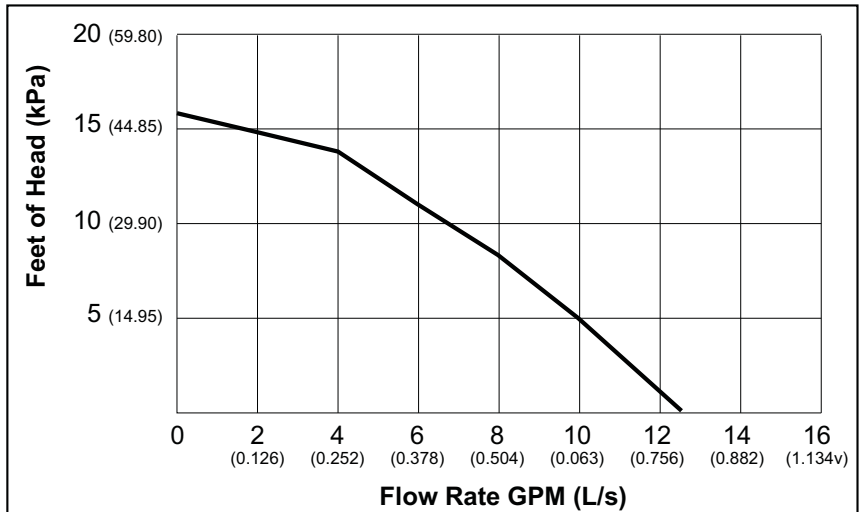

Figure 3: EWPK1 - Pump Curve



Note: Never use piping smaller than 1 inch. Limit length of pipe to 50 feet or less.

Potable Water Systems

The EW020 model is designed to provide primary hot water generation. An optional factory-installed desuperheater coil may be provided with an EW042 and EW060 to assist in the generation of domestic hot water.

With either option, the coaxial heat exchangers provide double-wall construction and are vented to allow installation in potable water applications. Figures 4 and 5 show how to connect a potable water system.

Figure 4: Suggested Domestic Water Heater Hookup

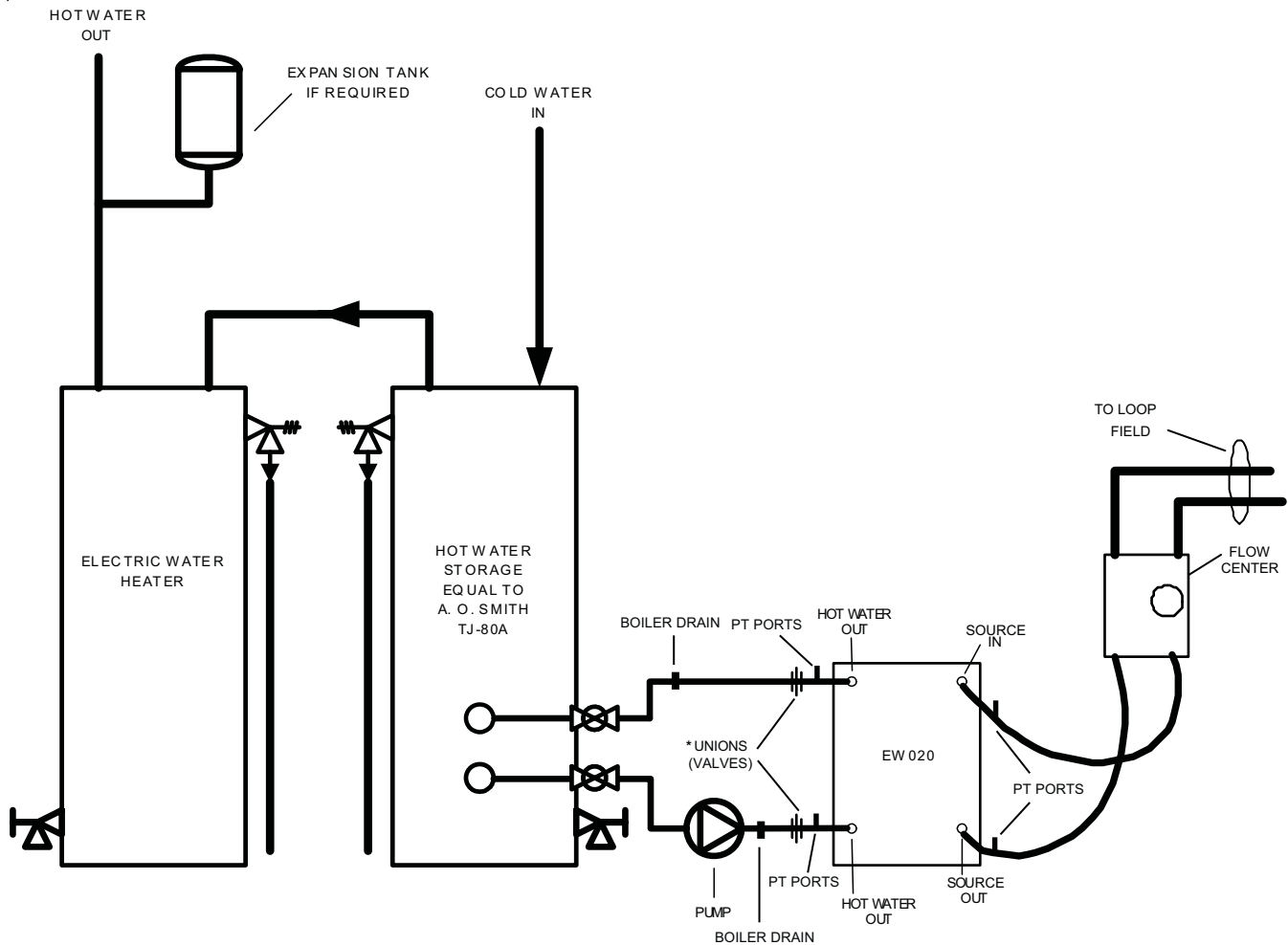

Notes: * Unions or valves must be installed so that acid flushing of the heat exchanger is possible.

Potable Water Systems

Figure 5: Alternate Hot Water Installation

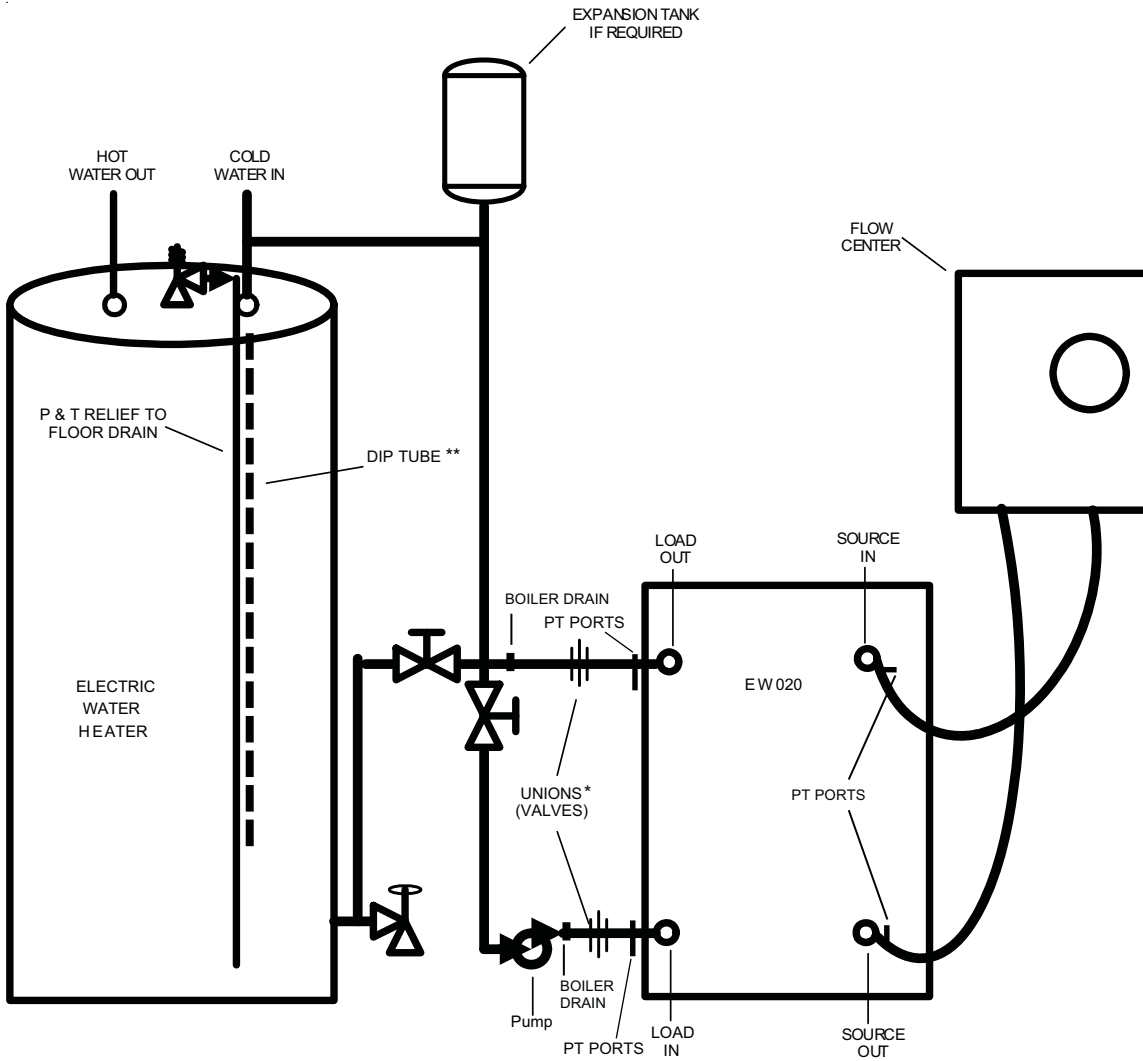

Note: * Unions or valves must be installed at the unit so acid flushing of the heat exchanger is possible.
 ** Make sure there is not a check valve in the diptube of the tank.

Open Loop - Well Water Systems

Always maintain water pressure in the heat exchanger by placing water control valves at the outlet of the unit. Use a closed bladder type expansion tank to minimize mineral deposits. Ensure proper water flow through the unit by checking pressure drop across the heat exchanger and comparing it to the figures in the capacity data tables in the specification catalog. Normally, about 2 GPM flow rate per ton of cooling capacity is needed in open loop systems, (1.5 GPM per ton minimum if entering source temperature is above 50°F [10°C]).

Some water control valves draw their power directly from the unit's 24V transformer and can overload and possibly burn out the transformer. Check total VA draw of the water valve(s) and ensure it is under 40 VA.

Discharge water from a heat pump can be disposed of in various ways depending on local building codes (i.e. recharge well, storm sewer, drain field, adjacent stream or pond, etc.). Most local codes restrict the use of sanitary sewer for disposal. Consult your local building and zoning departments to ensure compliance in your area.

Figure 6: Typical Open Loop Installation

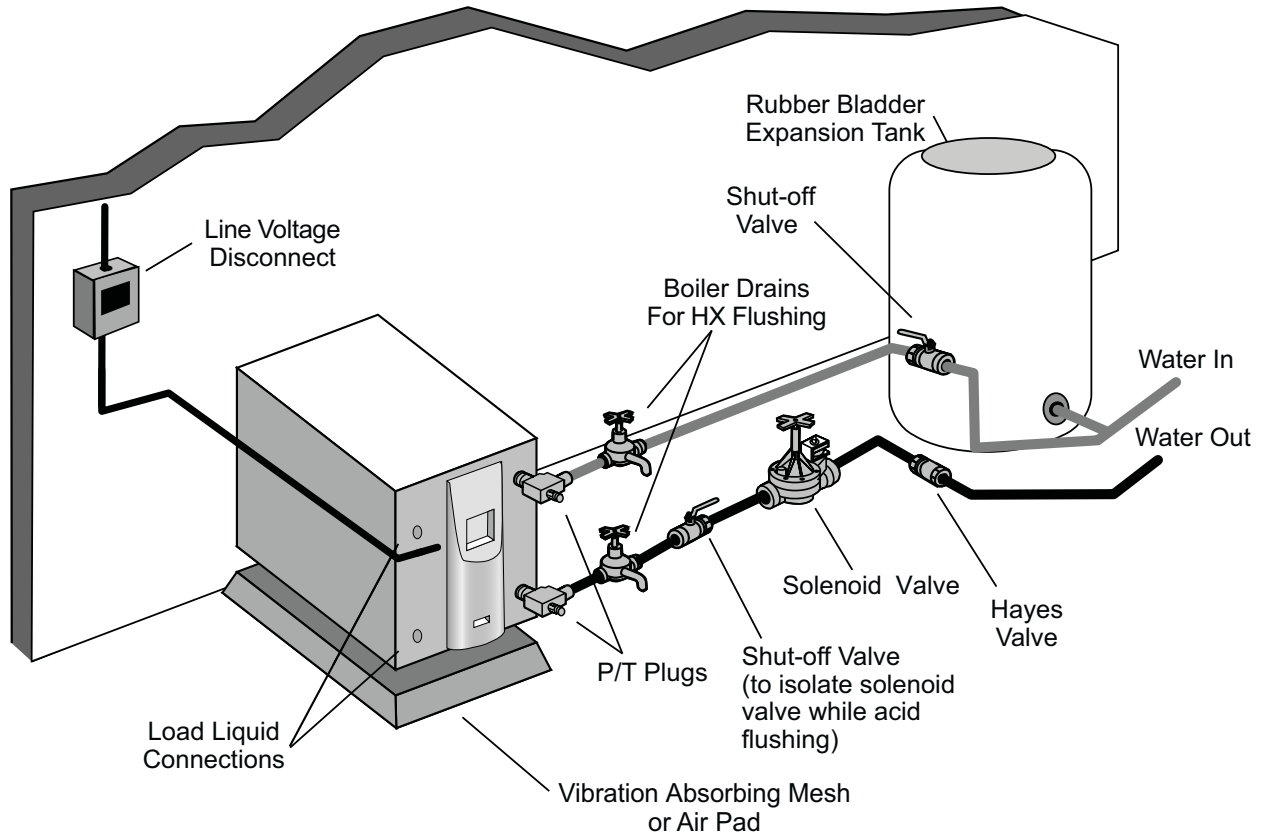

Earth-Coupled Systems with Flow Center

Once piping is completed between the unit, flow center and the earth loop, final purging and charging of the loop is needed. A flush cart (at least a 1.5 HP or 1.12 kW pump) is needed to achieve adequate flow velocity in the loop to purge air and dirt particles from the loop itself. Antifreeze solution is used in most areas to prevent freezing. Maintain the pH in the 7.6-8.2 range for final charging.

Flush the system adequately to remove as much air as possible. Then, pressurize the loop to a static pressure of 50-75 psi [345-517 kPa]. This is normally adequate for good system operation. Ensure that the flow center provides adequate flow through the unit by checking pressure drop across the heat exchanger and by comparing it to the figures shown in the tables on pages 22-24. Usually, 3 GPM/ton [0.054 L/s/kW] L/s/kW or minimum 2.25 GPM/ton [0.04 L/s/kW] of cooling capacity is needed in closed loop earth-coupled applications.

Figure 7: Typical Closed Loop Earth-Coupled Installation

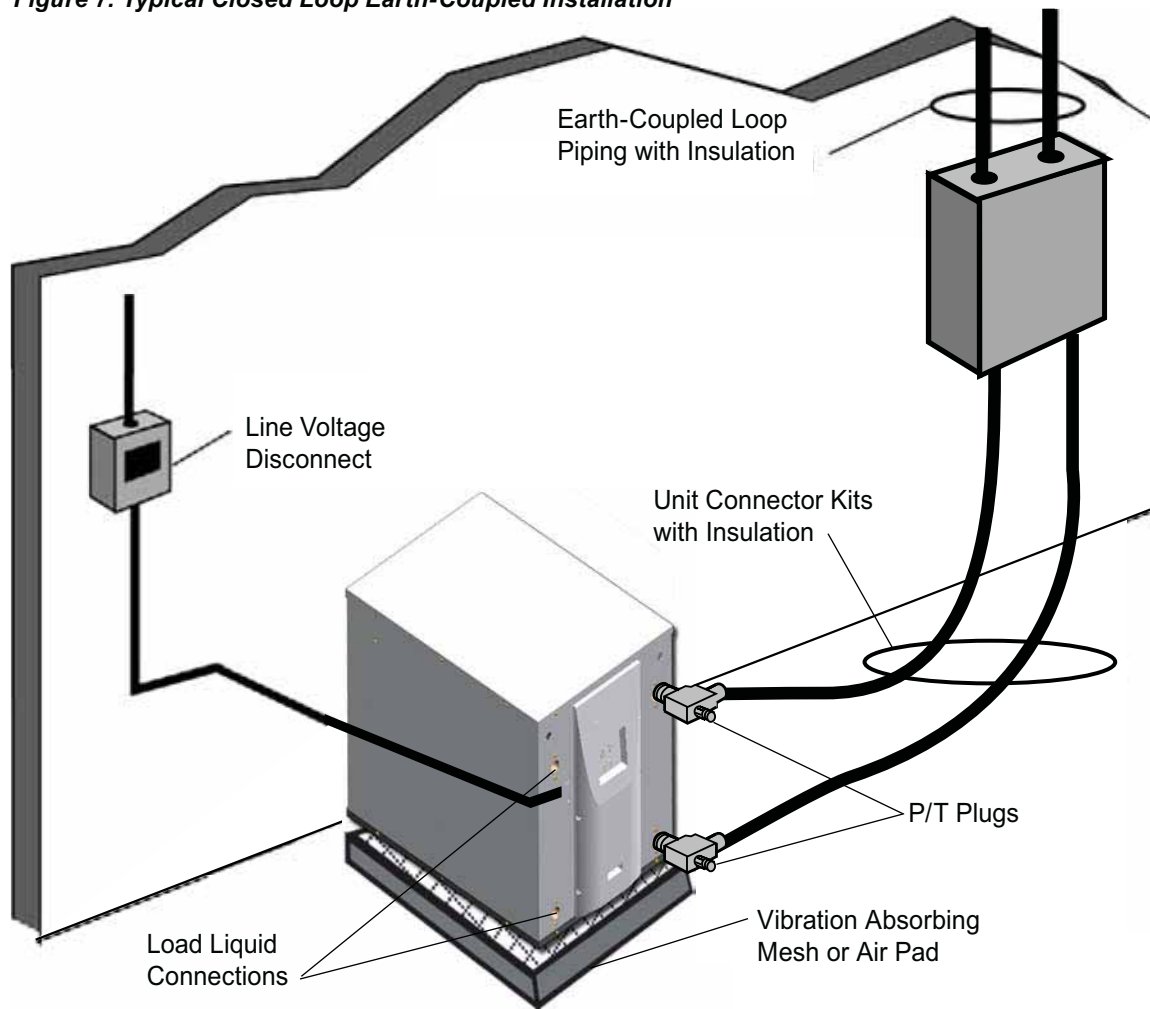

Electrical

MODEL	RATED VOLTAGE	VOLTAGE MIN/MAX	COMPRESSOR		LOAD PUMP	SOURCE PUMP	TOTAL UNIT FLA	MIN CIRCUIT AMP	MAX FUSE	MAX CIRCUIT BRKR
			RLA	LRA						
EW020	208-230/60/1	197/254	13.5	61.0	0.41	5.4	19.3	22.7	35	35
	265/1	239/292	10.9	58.0	-	-	10.9	13.6	20	20
	460/60/3	414/506	4.5	27.0	-	-	4.5	5.6	10	10
EW030	208-230/60/1	197/254	15.4	83.0	1.8	5.4	22.6	26.5	40	40
	265/60/1	239/292	15.4	83.0	-	-	15.4	19.3	30	30
	208-230/60/3	197/254	11.5	77.0	-	-	11.5	14.4	25	25
	460/60/3	414/506	5.1	35.0	-	-	5.1	6.4	10	10
EW042	208-230/60/1	197/254	26.9	145.0	1.8	5.4	34.1	40.8	60	60
	265/60/1	239/292	24.3	157.0	-	-	24.3	30.4	50	50
	208-230/60/3	197/254	17.6	123.0	-	-	17.6	22.0	35	35
	460/60/3	414/506	7.7	49.5	-	-	7.7	9.6	15	15
EW060	230/60/1	207/254	32	148.0	1.8	5.4	39.2	47.2	70	70
	265/60/1	239/292	20.2	160.0	-	-	20.2	25.3	45	45
	208-230/60/3	197/254	20.4	156.0	-	-	22.4	28.0	50	50
	460/60/3	414/506	10.6	75.0	-	-	10.6	13.3	20	20

Notes: All fuses are type "D" time delay (or HACR circuit breaker in USA).
 Source pump amps shown are for up to 1/2 HP pump.
 Load pump amps shown are for small circulators.
 EW060 is not rated for 208/60/1 operation.

208 Volt Operation

All 208-230 volt units are factory wired for 230 volt operation. To convert the unit from a 230V unit to a 208V unit follow these steps:

1. Remove the blue transformer wire from terminal L2 on the compressor contactor and secure the wire taking care to insulate the end with electrical tape.
2. Locate the red transformer wire and connect it to the L2 terminal of the compressor contactor.

Electrical

Be sure the available power is the same voltage and phase as that shown on the unit serial plate. Line and low voltage wiring must be done in accordance with local codes or the National Electric Code, whichever is applicable. Refer to the Unit Electrical Data on page 10 for wire and fuse or circuit breaker sizing information.

Flow Center Pump Operation

Two fuse internal terminal block connections with 1/4-inch spade connectors are provided; one for the load pump and one for the source pump. The source pump directly connects to the fuse terminal block for the source pump. The load pump directly connects to the fuse terminal block for the load pump.

EW Control Box Relocation

The EW control box can be installed on the rear of the unit. To relocate the control box, follow the procedures below.

1. Remove all power sources to the unit.
2. Remove the unit's top panel.
3. Cut all plastic wire **ties** to the following:
 - a) High pressure switch (black wires)
 - b) Low pressure switch (blue wires)
 - c) Freeze protection (yellow wires)
 - d) Load temperature sensor (black wires)
 - e) Compressor wires
4. Remove the four screws from the control box.
5. Relocate the control box to opposite end of the unit.
6. Using the screws removed in step 4 above, reattach the control box.
7. Secure all wires so they do not come in contact with refrigerant lines.
8. Replace the top of the unit.
9. Replace both access panels.
10. Reapply power sources.

Schematics

For all EW 208/230 volt single-phase units, the circulator wiring is as shown in Figures 8 and 9 below. The internal relay and fusing allow for external pumps no larger than .5 horsepower. The external loop pump connections mentioned in this manual include a dedicated flow center for each unit as well as an EW unit connected to a "P" or an "E" series unit containing a microprocessor. Figure 9 illustrates a dedicated flow center.

Figure 8: Load Circulator Wiring

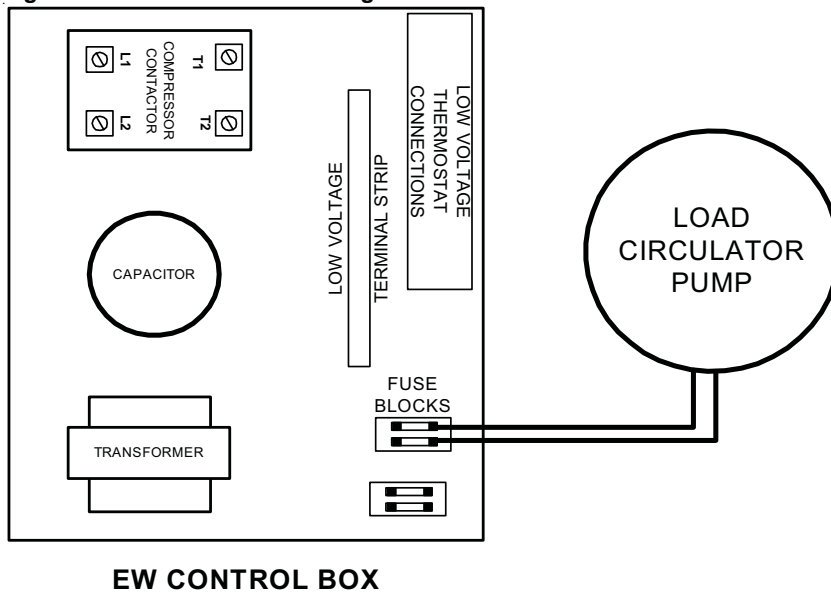
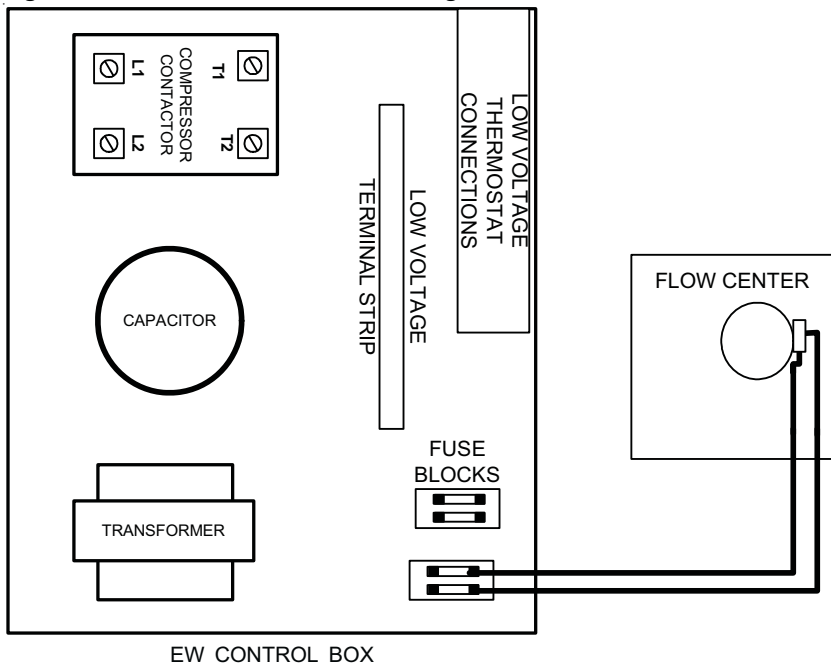
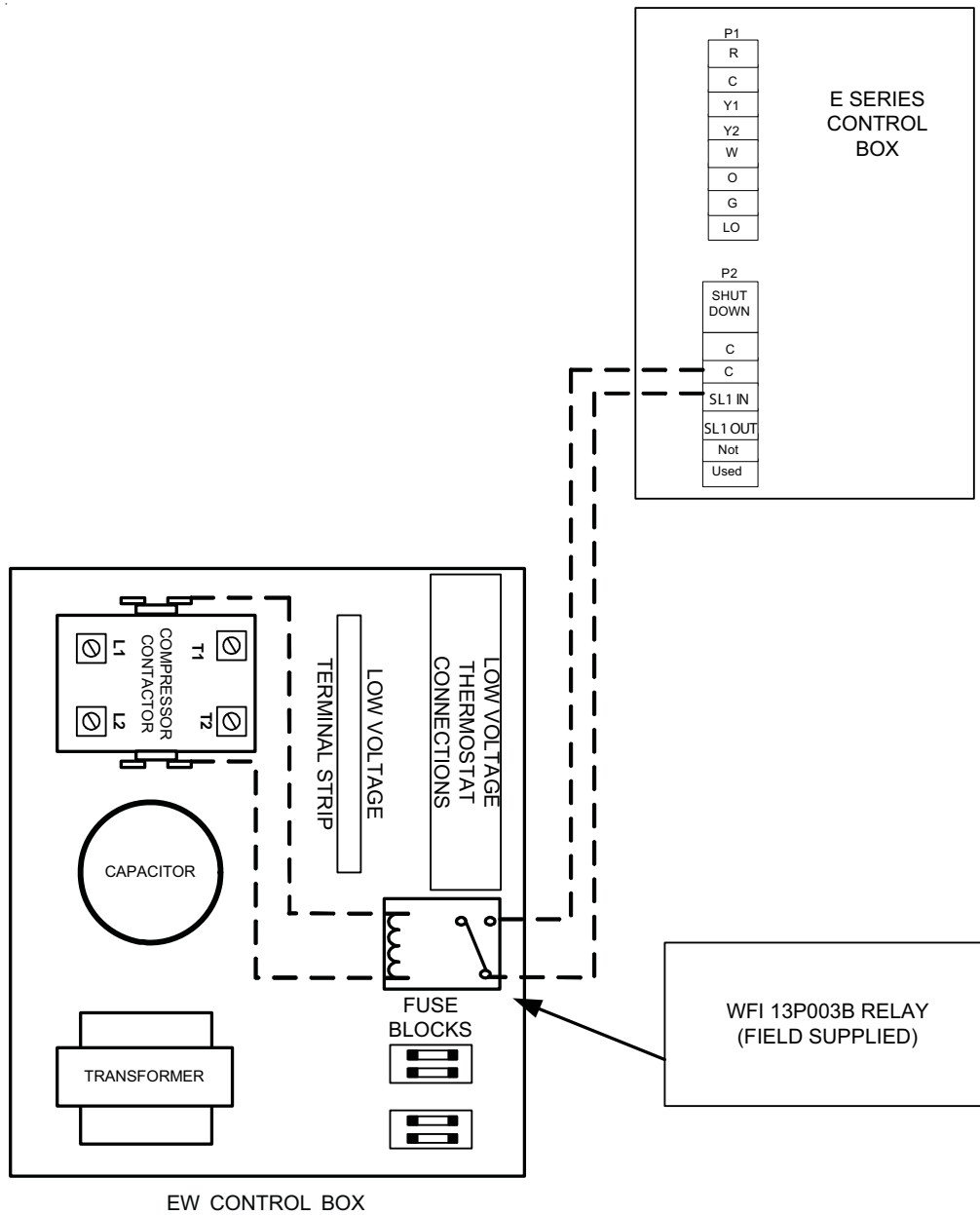

Figure 9: Dedicated Flow Center Wiring



Schematics

Figure 10: Multiple Units on a Single Flow Center Wiring



External Control

Primary Mode

In dedicated heating/cooling units, the unit is controlled by the internal controller. Compressor output is determined by the entering load-side water temperature.

The secondary output will be energized if two conditions occur:

1. The initial temperature is greater than IC away from the set point.
2. The change in temperature in a given period of time P is less than d .

In a reversible unit, the unit is controlled by the internal controller. Compressor output is determined by the entering load-side water temperature. For reversible units, the jumper wire must be positioned across terminals 6 & 7, (factory default set to this position). Reversible units do not have a secondary output.

Note: SL in the configuration menu must be set to 0, (factory default). All parameters should be checked for each application on primary unit, (refer to the parameter table on page 36).

Secondary Mode

In dedicated heating/cooling units, secondary mode allows the unit to be controlled by an external source. Compressor output is determined by the Y1 input only.

The secondary output will be energized after the following condition occurs:

1. The change in temperature in a given period of time P is less than d .

In reversible units, secondary mode allows the unit to be controlled by an external source. Compressor output is determined by the Y1 input and the reversing valve is determined by the O input. In reversible units, the jumper wire must be positioned across terminals 5 & 6. Reversible units do not have a secondary input.

Note: SL in the configuration menu must be set to 1. P and d must be setup for each secondary unit.

Figure 11: Aquastat Wiring for Dedicated Heating/Cooling Unit

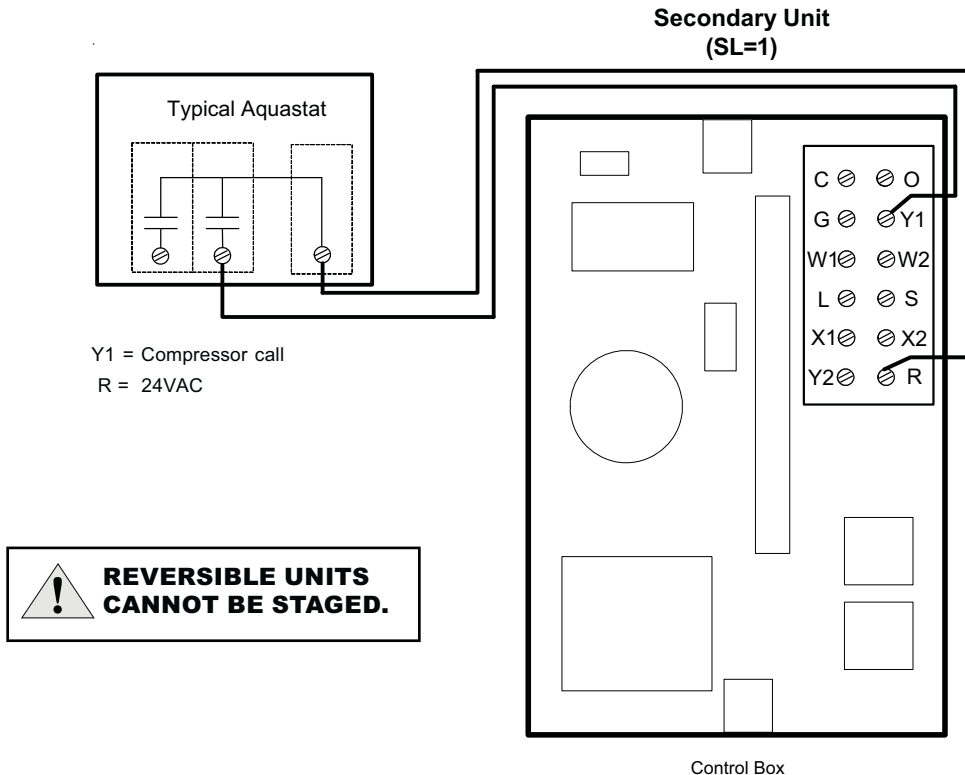

Wiring an Aquastat Reversible Unit

- To create a secondary unit, set SL to 1 in the configuration menu.
- Position the jumper wire in the control box across terminals 5 & 6.

Figure 12: Aquastat Wiring for Reversible Unit

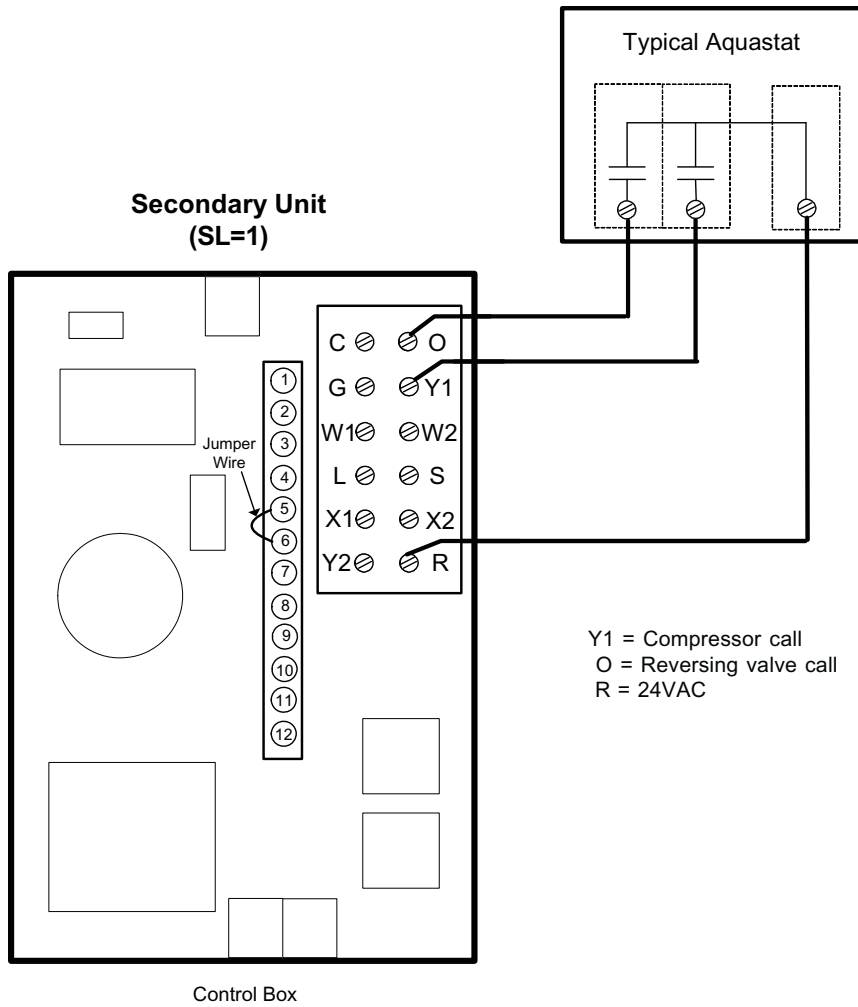

Note: Jumper wire must be moved to terminals 5 & 6.

Staging with Primary/Secondary Mode

Staging is only possible with dedicated heating/cooling units. **Reversible units cannot be staged.** Staging can be accomplished with primary/secondary modes or by using an aquastat.



CAUTION: Do not stage more than 6 units.

The first stage must be setup as a primary unit. All other units must be setup as secondary units. The set point is stored in the primary unit. Once the set point in the primary unit has been satisfied, all units will immediately shutdown. Figure 13 shows wiring with primary/secondary mode.

Figure 13: Wiring for Primary/Secondary Unit Staging

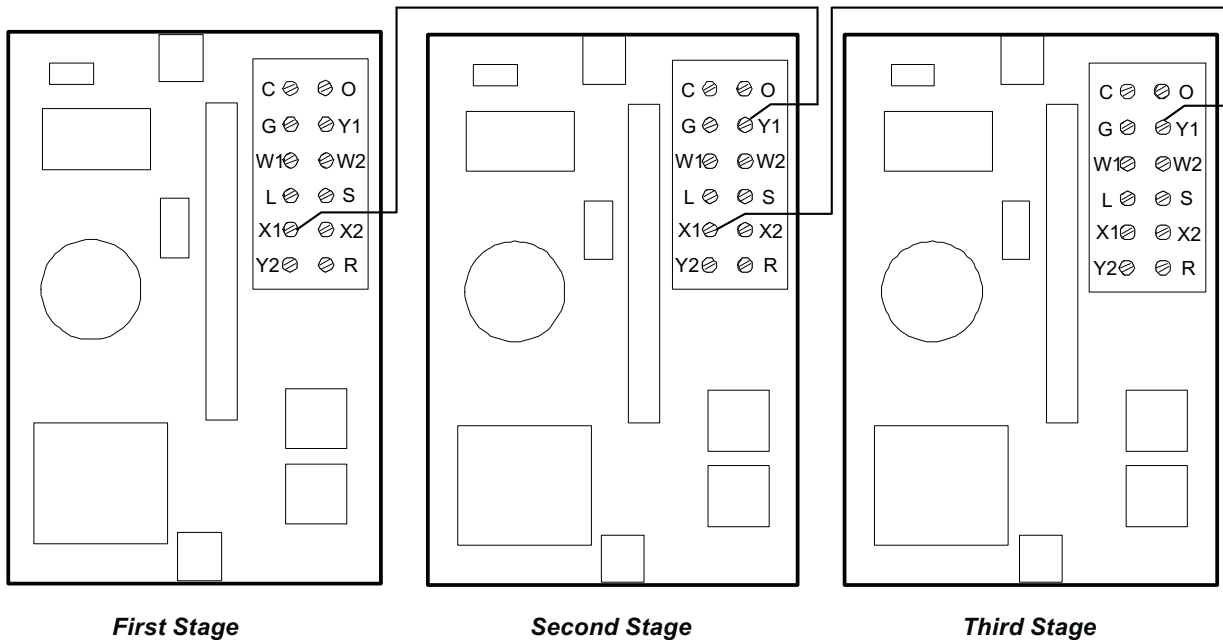

Notes: X1 = Secondary output
 Y1 = Compressor call

Staging with Aquastat

When staging units using an Aquastat, all units must be setup as secondary units. Figure 14 shows wiring for staging with an Aquastat.



CAUTION: Do not stage more than 6 units.

Figure 14: Wiring for Dedicated Heating/Cooling Units

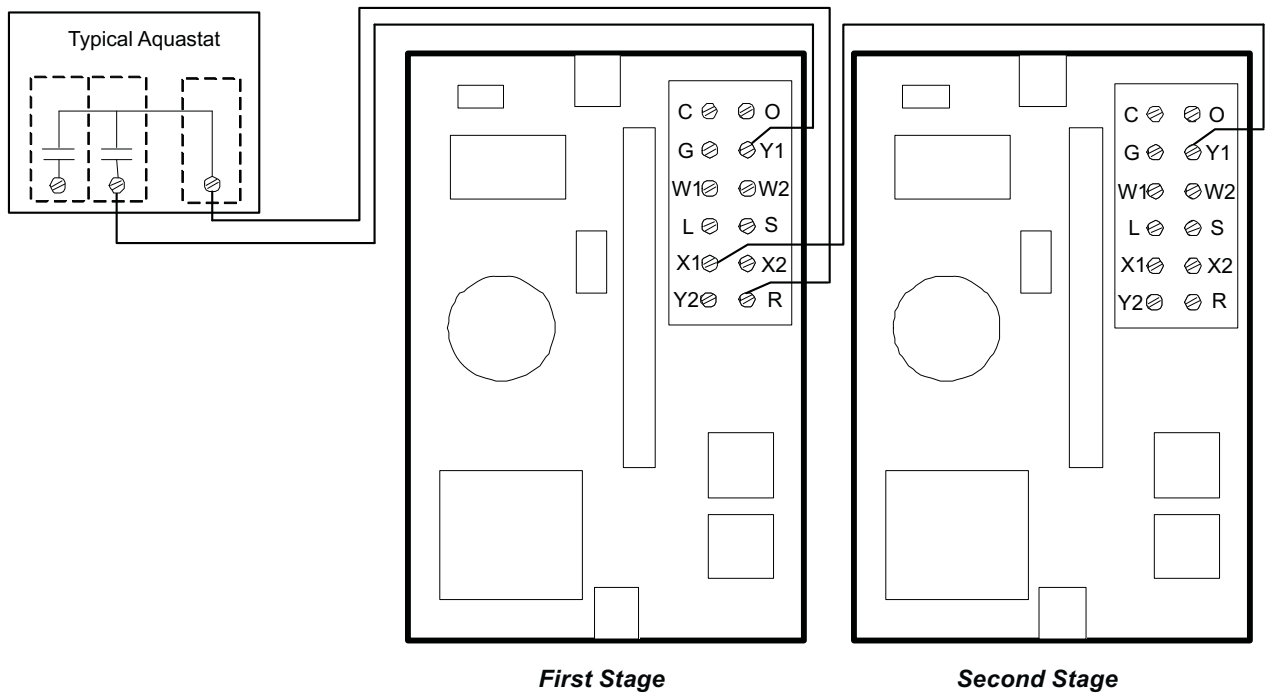

Notes: X1 = Secondary output
 Y1 = Compressor call
 R = 24 VAC

Converting to a Dedicated Cooling Unit

Procedure to Convert a Heating Only Unit to a Cooling Only Unit

All non-reversible EW units are built at the factory as dedicated heating units. Follow the procedures below to make the unit a dedicated cooling unit.

1. Shut off all power to the unit.
 2. Remove the top and access panel.
 3. Remove the brass in-well thermistor from the load water-in line.
 4. Remove the brass plug from the source water-in line.
 5. Place new Teflon® tape on the threads of the brass in-well thermistor.
 6. Thread the brass in-well thermistor into the source water-in line.
 7. Make sure the thermistor wires do not touch the discharge line.
 8. Place new Teflon® tape on the threads of the brass plug.
 9. Thread the brass plug into the load water-in line.
 10. Refer to the labels on the unit for the location of ports and lines.
 11. Connect the "Source Water-In" line to the port marked "Load Water-In". Then, connect the "Source Water-Out" line to the port marked "Load Water-Out".
 12. Connect the "Load Water-In" line to the port marked "Source Water-In". Then, connect the "Load Water-Out" line to the port marked "Source Water-Out".
 13. Open the control box.
 14. Find the connection marked "P4" as shown in Figure 15
 15. Move the "P4" jumper from across 1 and 2 to across 2 and 3.
 16. Close the control box and secure the screws.
 17. Replace the top and access panel.
 18. Make sure all screws have been re-installed.
 19. Turn on the power.
 20. Using the touch-pad, press the up arrow.
 21. The displays should blink "44" to show set point.
- Now, the unit should operate as a cooling only unit.

Figure 15: Control Board with Jumper

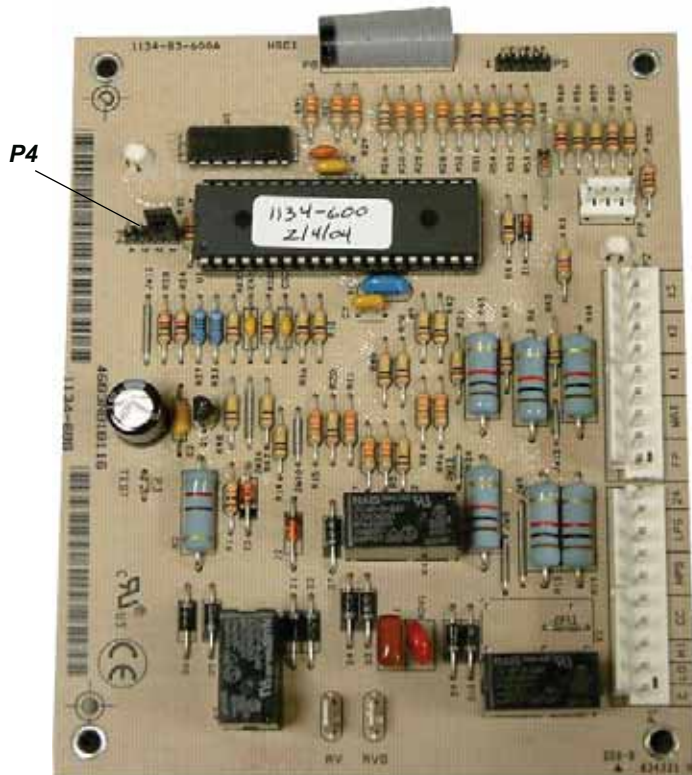

Jumper Pin Location

The location of the jumper pin determines the controller's mode of operation. Move the jumper pins to the correct location for dedicated heating, dedicated cooling or reversible settings as indicated below.

- Dedicated heating - 1 & 2 *
- Dedicated cooling - 2 & 3
- Reversible - 3 & 4 *

* Indicates factory setting.

Unit Startup

Before Powering Unit

Check the following:

- High voltage wiring is correct and matches the nameplate.
- Fuses, breakers and wire size are correct.
- Piping is completed and water system has been cleaned and flushed.
- Air is purged from the closed loop system.
- Isolation valves are open and loop water control valves or loop pumps are wired.
- Service/access panels are in place.

Primary Unit Startup

1. Apply power to the unit. Upon power up, the unit will display the current operation mode.
 - H for dedicated heating.
 - C for dedicated cooling.
 - U for reversible units.
2. Press the mode button. The LED screen will display the current entering water temperature. The load pump will activate after a 5 minute delay.
3. Once the load pump has been active for 3 minutes, the controller will sample the temperature of the water system. In heating mode, when the temperature of the water shown on the display is lower than the set point the compressor will activate.
4. By using a pressure gauge and the P/T ports, check the pressure drop through both the load and source coaxes. Compare this to the capacity tables in the specification catalog to verify the proper flow rate through the unit.
5. Verify that the compressor, load side and source side pumps are operating.
6. After determining the flow rates, use a thermometer and the PT ports to determine the change in temperature on both the load and source side coaxes.
7. Compute the formula **GPM flow rate X Change in temperature X 500 (485 on source side if antifreeze is used in the loop) = Heat of Extraction on the source side in heating, Heat of Rejection on the source side in cooling.** To ensure proper operation, compare these values to the capacity tables in the specification catalog.
8. Press the down arrow on the keypad to reduce the set point below the incoming load temperature. Compressor should shut off and the load pump should shut off 30 seconds after the compressor.
9. Wait 7 minutes. The load pump should start to sample load temperature.
10. Compressor and source side circulator should not start.
11. Press the up arrow on the keypad to increase the set point to 5 degrees above the water temperature displayed on the LED screen.
12. Three minutes after the load pump activates, the compressor and source pump should activate.

Secondary Unit Startup

1. Apply power to the unit.
2. After a three to five-minute delay, the water temperature shall be sampled. If the controller receives a remote aquastat signal, the compressor shall activate.
3. Verify that the compressor and load side, source side pumps are running.
4. By using a pressure gauge and the PT ports, check the pressure drop through both the load and source coaxes, and compare this to the capacity tables in the specification catalog to verify the proper flow rate through the unit.
5. After determining the flow rates, use a thermometer and the PT ports to determine the change in temperature on both the load and source side coaxes.
6. Compute the formula **GPM flow rate X Change in temperature X 500 (485 on source side if antifreeze is used in the loop) = Heat of Extraction on the source side in heating, Heat of rejection on the source side in cooling.** To ensure proper operation, compare these values to the capacity tables in the specification catalog.
7. Press the down arrow on the control to disrupt the remote aquastat signal. Unit should shut off.
8. Instruct the owner or operator about the correct control and system operation.

Control Panel

The control panel allows you to access the service menu on the unit. The control panel has three 7-segment LED screens that display the:

- Water temperature
- Configuration menu

There are 6 LED indicators that indicate when SECONDARY OUTPUT is active or the unit is on one of the following modes:

- Standby Mode
- Heating Mode
- Cooling Mode
- Primary (Master) Mode

The control panel has both UP and DOWN (arrow) buttons and a MODE button. The UP and DOWN buttons allow you to change the set point or scroll through the configuration menu. The MODE button allow you to change mode as well as enter and exit parameters while in configuration mode.

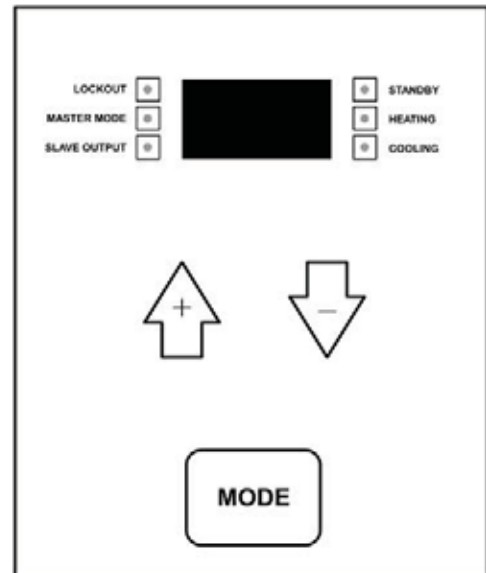

The Configuration Menu

The configuration menu allows you to properly set and adjust all of the unit's operating parameters to fit your application. To enter configuration mode and configure parameters, follow these procedures:

1. Hold down both the UP and DOWN buttons simultaneously for five seconds, or until the LED screen displays "LC".
2. Press the UP or DOWN arrow until "50" is displayed.
3. Press the MODE button. The screen should display "SC" to indicate the controller is in configuration mode.
4. Once in configuration mode, press the UP or DOWN arrow to scroll through the menu.
5. Press the MODE button to enter the parameter. (Refer to the parameter table on page 21 for a list of configurable parameters.)
6. Once in the parameter, press the UP or DOWN arrow to change the parameter.
7. Press the MODE button to return to the main menu.

Note: The controller will exit the configuration mode after 30 seconds if no key is pressed.

To Change the Set Point

1. Pressing the UP or DOWN arrow once will display the set point.
2. The set point will flash.
3. When the set point is flashing, the UP and DOWN arrow will change the set point by one degree.

Lockout Mode

During lockout mode, the display will flash the lockout code corresponding to the fault condition that caused the initial lockout. The compressor, loop pumps, and secondary output are de-energized.

Note: Lockout modes of any kind can be reset by pressing the mode button twice. Recycling the power also resets the lockout.

High Pressure

This lockout mode occurs when the normally closed safety switch is momentarily opened.

Low Pressure

This lockout occurs when the normally closed switch is opened for 30 continuous seconds.

Freeze Protection

This lockout mode occurs when the freeze thermistor temperature (located between the TXV and coax) is at or below the selected freeze protection point (Open Loop, Closed Loop, or Process) for 30 continuous seconds.

Remote Aquastat Secondary Mode (Y1)

The compressor shall engage 10 seconds after the Y1 call has been received. The compressor shall de-activate 10 seconds after the Y1 has been removed. The secondary output is controlled by a Derivative Controller. If the change in the water temperature is less than a selected value (d) in a selected period of time (P), the secondary output shall activate.

Parameter Functions and Settings

PARAMETER	FUNCTION	DESCRIPTION	FACTORY SETTING	RANGE	INCREMENTS
SC	Calibrate the Water Sensor	This will allow the temperature displayed to be adjusted to match a temperature reading from an external source.	0	-9 to 10	1
dB	Dead Band	This parameter is used to determine when the compressor should be activated. If the set point is below the set point minus the dB value (in heating mode) then the compressor will activate.	1	1 to 15	1
CF	Celsius/ Fahrenheit Selection	This parameter selects the units for which the temperature will be displayed.	F	F or C	N/A
FP	Freeze Protection Setting	There are three settings for this parameter; OL, CL, and P. OL is the open loop setting which corresponds to 30°F (0°C). CL is the closed loop setting which is 15°F (-10°C). P is the process setting which is 5°F (-15°C).	OL	P,CL,OL	N/A
SL	Primary/ Secondary Setting	Primary mode utilizes an internal aquastat to determine the activity of the compressor. In secondary mode the compressor output is determined by an external aquastat	0 (Primary)	0 or 1	0 = Primary 1 = Secondary
IC	Initial Condition	This parameter is used to determine the state of the secondary output of the primary unit. If the actual water temperature is greater than the IC value away from the set point, the secondary output will be activated.	10	0 to 20	1
d	Derivative	This parameter is used to determine the state of the secondary output of the primary and secondary unit. If the change in temperature is less than the "d" value the secondary output will activate.	1	0 to 5	1
P	Period	This determines how often the derivative will be calculated.	5 min	1 to 5 min	1 min
PS	Pump Sampling Time Selection	This parameter determines how long the pump is activated before the controller takes a sample of the water temperature. The range of this parameter is from 1 to 5 minutes and is factory set to 3 minutes. The pump can also be set to run continuously when PS is set to C.	3 min	1 to 5 min or C	1 min
Fd	Freeze Protection Display	This displays the current temperature of the freeze protection sensor.	N/A	0 to 130	N/A

Capacity Data

Heating Capacity Data

MODEL	SOURCE						LOAD						CAPACITY		COP
	FLOW			SWPD			FLOW			LWPD			HEAT OUTPUT	kW	
	EWT	GPM	L/s	PSI	FT HD	BAR	EWT	GPM	L/s	PSI	FT HD	BAR			
EW020	32	6	0.38	4.3	9.9	0.3	104	3	0.19	1.2	2.8	0.1	22.2	6.5	2.8
EW020	32	9	0.57	9.0	20.8	0.6	104	9	0.57	9	20.8	0.6	22.5	6.6	3.0
EW030	32	8	0.50	2.8	6.5	0.2	104	5	0.32	1.4	3.2	0.1	29.0	8.5	3.0
EW030	32	12	0.76	5.6	12.9	0.4	104	12	0.76	5.6	12.9	0.4	29.5	8.6	3.1
EW042	32	11	0.69	2.5	5.8	0.2	104	7	0.44	1.2	2.8	0.1	44.9	13.2	2.9
EW042	32	16.5	1.04	5.6	12.9	0.4	104	16.5	1.04	5.6	12.9	0.4	45.5	13.3	3.0
EW060 Single Phase	32	14	0.88	2.7	6.2	0.2	104	11	0.69	1.8	4.2	0.1	59.2	17.4	2.8
EW060 Single Phase	32	21	1.32	5.7	13.2	0.4	104	21	1.32	5.7	13.2	0.4	60.7	17.8	3.0
EW060 Three Phase	32	14	0.88	2.7	6.2	0.2	104	11	0.69	1.8	4.2	0.1	56.1	16.4	3.1
EW060 Three Phase	32	21	1.32	5.7	13.2	0.4	104	21	1.32	5.7	13.2	0.4	57.6	16.9	3.3

Notes: Based on 60 Hz.

For more detailed data, refer to the Specification Catalog SP1469.

Cooling Capacity Data

MODEL	SOURCE						LOAD						CAPACITY		EER
	FLOW			SWPD			FLOW			LWPD			MBTU	kW	
	EWT	GPM	L/s	PSI	FT HD	BAR	EWT	GPM	L/s	PSI	FT HD	BAR			
EW030	77	8	0.50	2.8	6.5	0.2	53.6	8.0	0.50	2.8	6.5	0.2	21.9	6.42	10.67
EW030	77	12	0.76	5.6	12.9	0.4	53.6	12.0	0.76	5.6	12.9	0.4	22.1	6.48	10.93
EW042	77	11	0.69	2.5	5.8	0.2	53.6	11.0	0.69	2.5	5.8	0.2	42.7	12.51	12.42
EW042	77	16.5	1.04	5.6	12.9	0.4	53.6	16.5	1.04	5.6	12.9	0.4	43.2	12.66	12.86
EW060 Single Phase	77	14	0.88	2.7	6.2	0.2	53.6	14.0	0.88	2.7	6.2	0.2	58.0	17.00	12.54
EW060 Single Phase	77	21	1.32	5.7	13.2	0.4	53.6	21.0	1.32	5.7	13.2	0.4	61.1	17.91	13.47
EW060 Three Phase	90	14	0.88	2.7	6.2	0.2	53.6	14.0	0.88	2.7	6.2	0.2	55.7	16.32	10.46
EW060 Three Phase	77	21	1.32	5.7	13.2	0.4	53.6	21.0	1.32	5.7	13.2	0.4	61.1	17.91	13.47

Notes: Based on 60 Hz.

For more detailed data, refer to the Specification Catalog SP1469.

Flow Rates and Pressure Drop

The following tables list the required minimum flow rates (GPM) for all combinations of source temperatures from 30°F to 110°F [-1°C to 43°C] and load temperatures from 100°F to 130°F [38°C to 54°C]. For example, on an EW020, heating water to a temperature of 125°F [52°C] with a 70°F [21°C] source temperature requires a minimum flow of 3.5 GPM. Refer to the tables on page 24 for required source side flow rates.



WARNING: Operating the unit outside of the minimum flow rate parameters will trip the high pressure switch and/or result in compressor damage.

EW020 Minimum Load Flow

SOURCE EWT	MAX HEATING SET POINT													
	100°F		105°F		110°F		115°F		120°F		125°F		130°F	
	GPM	WPD	GPM	WPD	GPM	WPD	GPM	WPD	GPM	WPD	GPM	WPD	GPM	WPD
30°F	1.5	0.3	1.5	0.3	1.5	0.3	1.5	0.3	1.5	0.3	1.5	0.3	2.0	0.6
40°F	1.5	0.3	1.5	0.3	1.5	0.3	1.5	0.3	1.5	0.3	2.0	0.6	2.5	0.8
50°F	1.5	0.3	1.5	0.3	1.5	0.3	1.5	0.3	2.0	0.6	2.5	0.8	3.0	1.2
60°F	1.5	0.3	1.5	0.3	1.5	0.3	2.0	0.6	2.5	0.8	3.0	1.2	3.5	1.6
70°F	1.5	0.3	1.5	0.3	2.0	0.6	2.5	0.8	3.0	1.2	3.5	1.6	4.0	2.0
80°F	1.5	0.3	2.0	0.6	2.5	0.8	3.0	1.2	3.5	1.6	4.0	2.0	6.0	4.3
90°F	2.0	0.6	2.5	0.8	3.0	1.2	3.5	1.6	4.0	2.0	6.0	4.3	7.0	5.7
100°F	2.5	0.8	3.0	1.2	3.5	1.6	4.0	2.0	6.0	4.3	7.0	5.7	7.5	6.4
110°F	3.0	1.2	3.5	1.6	4.0	2.0	6.0	4.3	7.0	5.7	7.5	6.4	9.0	9.0

EW030 Minimum Load Flow

SOURCE EWT	MAX HEATING SET POINT													
	100°F		105°F		110°F		115°F		120°F		125°F		130°F	
	GPM	WPD	GPM	WPD	GPM	WPD	GPM	WPD	GPM	WPD	GPM	WPD	GPM	WPD
30°F	2.5	0.3	2.5	0.3	2.5	0.3	2.5	0.3	2.5	0.3	2.5	0.3	3.0	0.5
40°F	2.5	0.3	2.5	0.3	2.5	0.3	2.5	0.3	2.5	0.3	3.0	0.5	3.5	0.8
50°F	2.5	0.3	2.5	0.3	2.5	0.3	2.5	0.3	3.0	0.5	3.5	0.8	4.5	1.0
60°F	2.5	0.3	2.5	0.3	2.5	0.3	3.0	0.5	3.5	0.8	4.5	1.0	5.5	1.4
70°F	2.5	0.3	2.5	0.3	3.0	0.5	3.5	0.8	4.5	1.0	5.5	1.4	6.5	2.0
80°F	2.5	0.3	3.0	0.5	3.5	0.8	4.5	1.0	5.5	1.4	6.5	2.0	9.0	3.6
90°F	3.0	0.5	3.5	0.8	4.5	1.0	5.5	1.4	6.5	2.0	9.0	3.6	11.0	5.2
100°F	3.5	0.8	4.5	1.0	5.5	1.4	6.5	2.0	9.0	3.6	11.0	5.2	11.5	5.6
110°F	4.5	1.0	5.5	1.4	6.5	2.0	9.0	3.6	11.0	5.2	11.5	5.6		

EW042 Minimum Load Flow

SOURCE EWT	MAX HEATING SET POINT													
	100°F		105°F		110°F		115°F		120°F		125°F		130°F	
	GPM	WPD	GPM	WPD	GPM	WPD	GPM	WPD	GPM	WPD	GPM	WPD	GPM	WPD
30°F	3.5	0.3	3.5	0.3	3.5	0.3	3.5	0.3	3.5	0.3	3.5	0.3	4.5	0.5
40°F	3.5	0.3	3.5	0.3	3.5	0.3	3.5	0.3	3.5	0.3	4.5	0.5	5.5	0.7
50°F	3.5	0.3	3.5	0.3	3.5	0.3	3.5	0.3	4.5	0.5	5.5	0.7	6.5	1.0
60°F	3.5	0.3	3.5	0.3	3.5	0.3	4.5	0.5	5.5	0.7	6.5	1.0	7.5	1.3
70°F	3.5	0.3	3.5	0.3	4.5	0.5	5.5	0.7	6.5	1.0	7.5	1.3	8.5	1.7
80°F	3.5	0.3	4.5	0.5	5.5	0.7	6.5	1.0	7.5	1.3	8.5	1.7	12.5	3.4
90°F	4.5	0.5	5.5	0.7	6.5	1.0	7.5	1.3	8.5	1.7	12.5	3.4	14.5	4.4
100°F	5.5	0.7	6.5	1.0	7.5	1.3	8.5	1.7	12.5	3.4	14.5	4.4	16.5	5.6
110°F	6.5	1.0	7.5	1.3	8.5	1.7	12.5	3.4	14.5	4.4	16.5	5.6		

Note: All pressure drops are in PSI.

EW060 Minimum Load Flow

SOURCE EWT	MAX HEATING SET POINT													
	100°F		105°F		110°F		115°F		120°F		125°F		130°F	
	GPM	WPD	GPM	WPD	GPM	WPD	GPM	WPD	GPM	WPD	GPM	WPD	GPM	WPD
30°F	5.5	0.5	5.5	0.5	5.5	0.5	5.5	0.5	5.5	0.5	5.5	0.5	6.0	0.6
40°F	5.5	0.5	5.5	0.5	5.5	0.5	5.5	0.5	5.5	0.5	6.0	0.6	7.5	0.9
50°F	5.5	0.5	5.5	0.5	5.5	0.5	5.5	0.5	6.0	0.6	7.5	0.9	9.0	1.3
60°F	5.5	0.5	5.5	0.5	5.5	0.5	6.0	0.6	7.5	0.9	9.0	1.3	10.5	1.7
70°F	5.5	0.5	5.5	0.5	6.0	0.6	7.5	0.9	9.0	1.3	10.5	1.7	12.0	2.1
80°F	5.5	0.5	6.0	0.6	7.5	0.9	9.0	1.3	10.5	1.7	12.0	2.1	18.0	4.3
90°F	6.0	0.6	7.5	0.9	9.0	1.3	10.5	1.7	12.0	2.1	18.0	4.3	21.0	5.7
100°F	7.5	0.9	9.0	1.3	10.5	1.7	12.0	2.1	18.0	4.3	21.0	5.7		
110°F	9.0	1.3	10.5	1.7	12.0	2.1	18.0	4.3	21.0	5.7				

Source Flow Rates

MODEL	MINIMUM OPEN LOOP FLOW RATE	MINIMUM CLOSED LOOP FLOW RATE	MAXIMUM FLOW RATE
EW020	3.0	6.0	9.0
EW030	4.0	8.0	12.0
EW042	5.5	11.0	16.5
EW060	7.0	14.0	21.0

Pressure Drop (PSI)

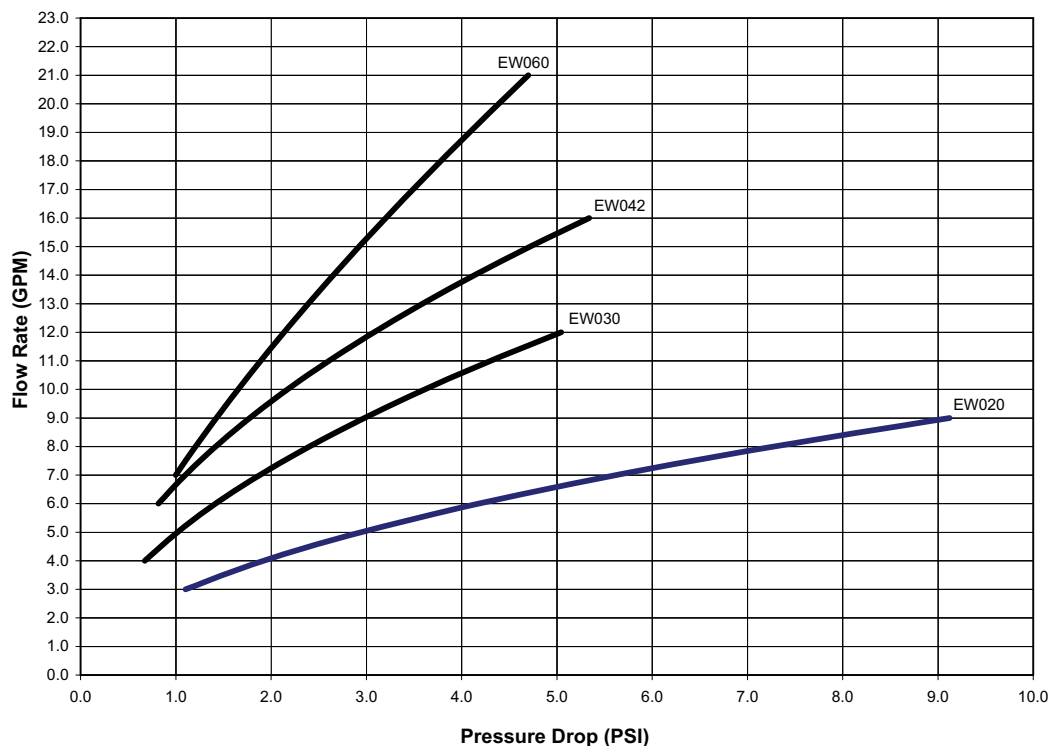

Troubleshooting

Should a major problem develop, refer to the following information for possible causes and corrective steps:

Compressor Won't Run:

1. The fuse may be blown or the circuit breaker is open. Check electrical circuits and motor windings for shorts or grounds. Investigate for possible overloading. Replace fuse or reset circuit breakers after the fault is corrected.
2. Supply voltage may be too low. Check voltage with a volt meter.
3. Remote control system may be faulty. Check aquastat for correct wiring, setting and calibration. Check 24-volt transformer for burnout.
4. Wires may be loose or broken. Replace or tighten.
5. The low pressure switch may have tripped due to one or more of the following:
 - a. Fouled or plugged coaxial heat exchangers
 - b. Low or no water flow (source side heating, load side cooling)
 - c. Water too cold (source side heating)
 - d. Low refrigerant
6. The high pressure switch may have tripped due to one or more of the following:
 - a. Fouled or plugged coaxial heat exchanger
 - b. Low or no water flow (source side cooling, load side heating)
 - c. Water too warm (source side cooling)
7. Check the capacitor.
8. The compressor overload protection may be open. If the compressor dome is extremely hot, the overload will not reset until cooled down. If the overload does not reset when cool, it may be defective. If so, replace the compressor.
9. The internal winding of the compressor motor may be grounded to the compressor shell. If so, replace the compressor.
10. The compressor winding may be open. Check continuity with an ohm meter. If the winding is open, replace the compressor.

Insufficient Cooling or Heating

1. Check aquastat for improper location (secondary mode only).
2. Check for restriction in water flow.
3. Check subcooling for low refrigerant charge.
4. The reversing valve may be defective and creating a bypass of refrigerant. If the unit will not cool, check the reversing valve coil.
5. Check thermal expansion valve for possible restriction of refrigerant flow.

Noisy Unit Operation

1. Check compressor for loosened mounting bolts. Make sure compressor is floating free on its isolator mounts.
2. Check for tubing contact with the compressor or other surfaces. Readjust it by bending slightly.
3. Check screws on all panels.
4. Check for chattering or humming in the contactor or relays due to low voltage or a defective holding coil. Replace the component.
5. Check for proper installation of vibration absorbing material under the unit. Unit must be fully supported, not just on corners.
6. Check for abnormally high discharge pressures.

Troubleshooting Controls

Check the unit. If a lockout mode is displayed, refer to the table below to determine the meaning of the failure. Follow the procedure listed to correct the problem.

Check the mode:

1. If the unit is running on the internal aquastat, verify the unit is in "Primary" mode. The SL should be set to 0 in the setup menu.
2. If the unit is running on an external aquastat, the SL should be set to 1.

Check the jumpers on the control board:

1. Refer to Figure 15 on page 18 to see the location of the jumper on the board. If the unit is a heating only unit, the jumper should be across 1 and 2.
2. If the unit is a cooling only unit, the jumper should be across 2 and 3.
3. If the unit is a reversible unit, the jumper should be across 3 and 4.

Check the thermistor calibration:

1. Using a thermometer in the P/T port, check the incoming water temperature.
2. Verify that the measured temperature is within 3 degrees of the temperature displayed on the unit.
3. If it is not, adjust the calibration in the setup menu.

DISPLAY	FAILURE	DIAGNOSTIC
DC	Freeze protection thermistor is closed (shorted)	Replace the freeze protection thermistor (clip-on thermistor)
DO	Freeze protection thermistor is open	Verify that the freeze protection thermistor is secured properly in the board connector. If the connection is secure, replace the thermistor.
FP	Freeze protection.	The water going through the unit has reached the freeze point setting (P=5, CL=15, OL=30). Verify that the freeze protection setting is correct for the application.
HC	Water set point thermistor is closed (shorted)	Replace the water set point thermistor (threaded thermistor).
HP	High Pressure	The unit has cut out on high pressure. Discharge pressure is >600.
LP	Low Pressure	The unit has cut out on low pressure. Suction pressure is <40
PO	Water set point thermistor is open	Verify that the water set point thermistor is properly secured in the board connector. If the connection is secure, replace the thermistor.

Preventive Maintenance

1. Keep all air out of the water lines. An open loop system should be checked to ensure that the well head is not allowing air to infiltrate the water line. Lines should always be airtight.
2. Keep the system under pressure at all times. In open loop systems, it is recommended that a water control valve be placed in the discharge line to prevent loss of pressure during off cycles. Closed loop systems must have a positive static pressure.

Note: If the installation is performed in an area with a known high mineral content in the water, it is best to establish a periodic maintenance schedule to check the water-to-refrigerant heat exchanger on a regular basis. Should periodic cleaning be necessary, use standard cleaning procedures which are compatible with either the cupronickel or copper water lines. Generally, the more water flowing through the unit, the less chance there is for scaling. Low GPM flow rates produce higher temperatures through the coil. To avoid excessive pressure drop and the possibility of copper erosion, do not exceed GPM flow rate as shown on the specification sheets for each unit.

Cleaning Procedure

1. Close the inlet and outlet water valves to isolate the heat pump from the well system, water heater or loop pumps.
2. Disconnect piping and remove solenoid valve, pumps, etc, from the inlet and outlet connections on the heat pump.
3. Connect plastic hoses from the circulating pump* to the outlet of the water-to-refrigerant heat exchanger to be de-limed (refer to Figure 16).
4. Connect a plastic hose from the circulating pump inlet to the bottom of a plastic five(5) gallon pail (refer to Figure 16).
5. Connect a plastic hose from the inlet line of the water-to-refrigerant heat exchanger to the plastic pail. Secure tightly to ensure that circulating solution does not spill (refer to Figure 16).
6. Partially fill the plastic pail with clear water (about two-thirds full) and prime the circulating pump. Circulate until lines are full.
7. Start the circulating pump and slowly add a commercial scale remover** to the water as recommended by the scale remover manufacturer's directions.
8. Be sure the pump circulation is opposite to the normal water flow through the water-to-refrigerant heat exchanger.
9. Maintain re-circulation until all scale and other material has been dissolved and flushed from the heat exchanger.
10. Upon completion of the procedure. Safely dispose of the solution.
11. Rinse the pump and plastic pail. Refill with clear water.
12. Start the pump circulation and flush the system until all acid residue has been removed from the system. Refill the plastic pail until only clear water is circulated.
13. Turn off the circulating pump and disconnect all hoses and fittings.
14. Replace solenoid valves, pumps, hoses and other devices in their original locations. On closed loop systems, be sure to purge between the flow center and unit to avoid getting air into the loop.
15. Put the heat pump back into operation. Check for proper operating temperature.



WARNING: This process involves a caustic solution and may be harmful to people and animals. Wear protective equipment (glasses, rubber gloves, apron, etc.)

Figure 16: Cleaning Connections

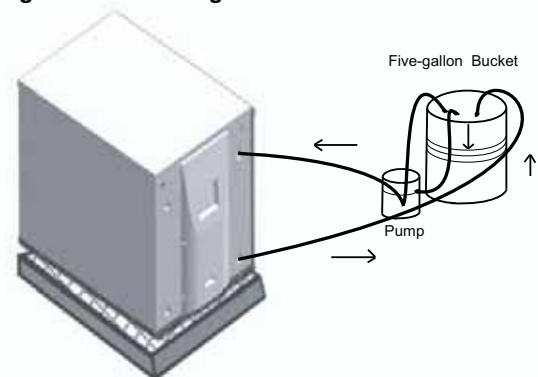

Notes: *Virginia Chemical Co. makes a Pump model H460.

* W.W. Granger Co. sells a Pump #2P-017 made by Little Giant.

**Virginia Chemical Co. makes a liquid ice machine cleaner which should be used on water-to-refrigerant heat exchangers serving a domestic hot water system. Calci-Solve by NYCO is available for use on other heat exchangers

GEO*SMART* **E N E R G Y**

**290 Pinebush Road
Cambridge, Ontario, N1T 1Z6
1.866.310.6690
www.geosmartenergy.com**



WFI has a policy of continuous product research and development and reserves the right to change design and specifications without notice.
©2004 WFI.

Product: Premium EW
Type: Hydronic Heat Pumps
Size: 2 thru 5 Ton

Document Type: Installation Manual
Part Number: IM1469
Release Date: 09/04
Supercedes: S11469 (06/04)